

LOVEJOY

Special Cutting Tools



LOVEJOY
Precision Cutting Tools

Special Tools Powered by **LOVEJOY** know-how

The Right Tool for the Right Job.

No matter how broad the standard tool offering, some applications are best served by special cutting tools. 55" diameter and more. 1" and less. Achieving savings with multiple features in one tool. Special inserts with standard bodies. Tools to reduce operations, improve cycle times and more. Lovejoy. The right tool for the right results.

Special Design to Production

From inquiry to delivery Lovejoy specials know-how works for you. A wide and deep experience base. Proven expertise with software and hardware to design and produce your special tool.

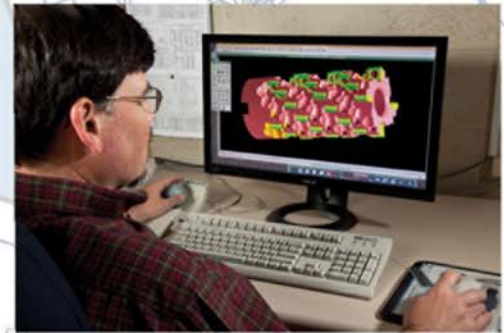
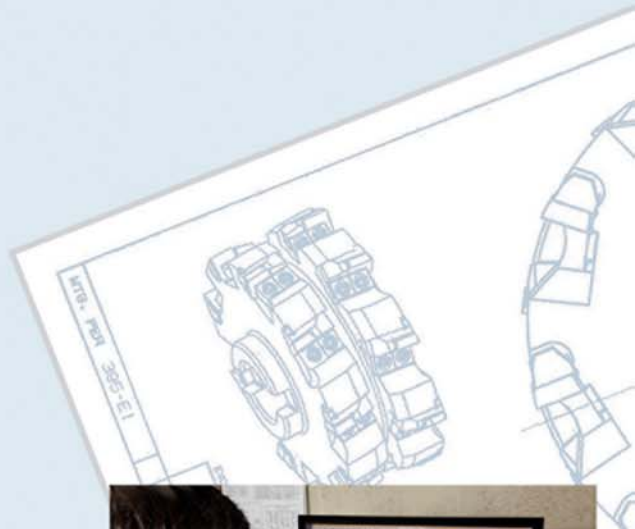

Powerful CAD systems bringing designs to production



Our CMM process in one of many quality control standards



5 Axis CNC Machining Center making complex machining simple



Dedicated EDM for cutting special tools intricate contours

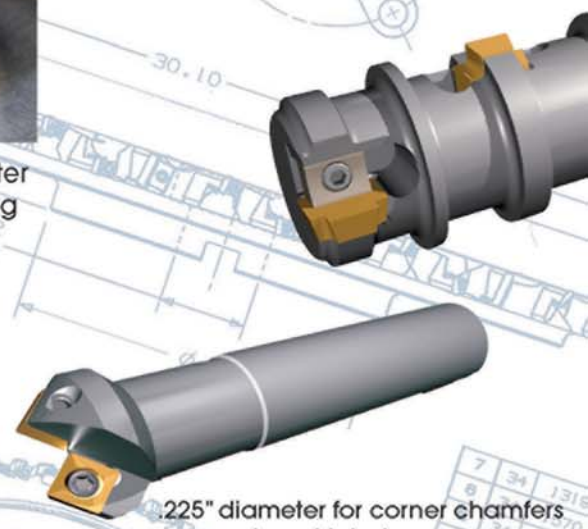

.225" diameter for corner chamfers in restricted space

Technical drawing details including:
R.075 TYP
3.00
500
30.10
2.5008
31 PER MODEL -
SIZE POCKET WITH PARTS
X DRILL PER
LOVEJOY

7	34	1315
8	7	1370
3	17	1365 (NEW)
2	17	1450
1	17	16180
1788	QTY.	PART NO.
		SPE-B44

Special Tools on the Job. Cutting* Costs. Increasing Production. Solving Problems.



"Dovetail" cutter for adding special angles



Adjustable cartridge boring tool with ISO cartridges



Inside cutter for two diameter simultaneous machining

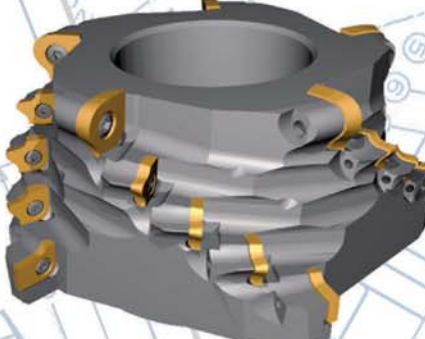

Unique cutter to make secure fit on spinning parts



Machines four grooves at one time at different widths



Boring tool that places chamfer as it bores



55" diameter cutter utilizing standard ISO inserts and common support hardware

Special cutter chamfers both edges of plate simultaneously



LOVEJOY

Standard Cutting Tools



AD 1241

Lovejoy standard milling tools, inserts and PCD/CBN tooling serve a wide range of application requirements across today's leading manufacturing industries.

Contact Lovejoy Tool and profit from our experience in machining cast iron, super alloys, composites, aluminum, steels, stainless steel and non-ferrous metals.



LOVEJOY Tool Company, Inc.
www.lovejoytool.com
(800) 843-8376

ISO 9001: 2008 Registered Company